

## Law Enforcement Click Pen Kit

Product : #163655

10/19/201



### From Setup To Sanding:

These are the supplies we suggest you have on hand to complete this pen kit:

- $\frac{3}{8}$ " Pen Maker's Bit
- $\frac{3}{4}$ " x  $\frac{3}{4}$ " x  $2\text{-}\frac{1}{4}$ " Pen Blank
- Pen Mandrel
- Law Enforcement Pen Kit Bushings (163656)
- Thick CA or 5 Minute Epoxy
- Drill or Drill Press
- Sandpaper/Micro-Mesh
- Barrel Trimmer / Pen Mill Pilot Shaft .338" Diameter (161547)
- Pen Press
- Eye & Ear Protection
- Dust Mask

### Cutting & Drilling Blanks:

Note: Additional length has been added to the overall length of the blank to accommodate for squaring the ends of the blank.

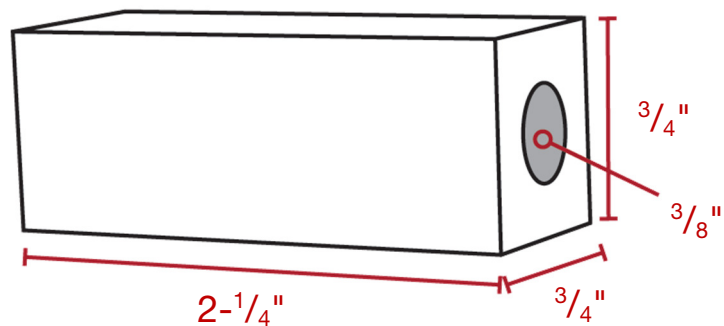
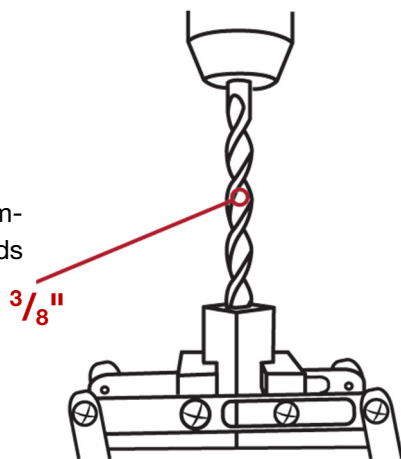

### Gluing Blanks to Tubes:

Rough the entire surface of the tube using 180-grit paper. Next, using either a thick CA or 5 Minute Epoxy, apply adhesive to both the tube and the inside of the blank. To secure the brass tube be sure to rotate the tube as you insert it into the blank. This will help ensure even coverage of the adhesive and a much more secure bond.

### Squaring the Blank to Length:

When squaring the blanks work only to the brass. Removing brass will affect the overall length of the blank which is critical to the proper operation of the pen. **If using a barrel trimmer/pen mill use a .338" diameter (161547).**

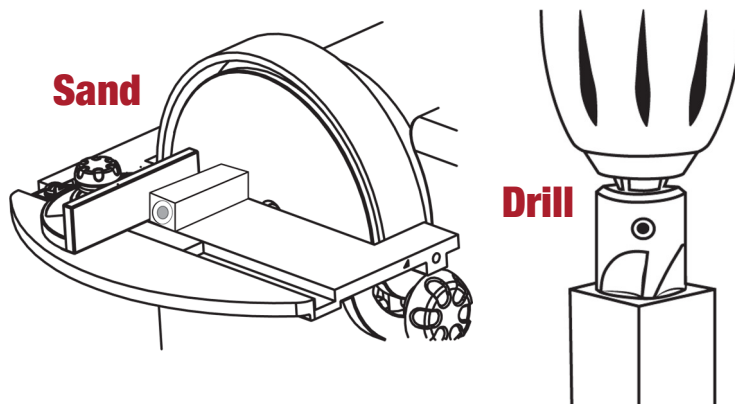

### Mandrel Preparation:

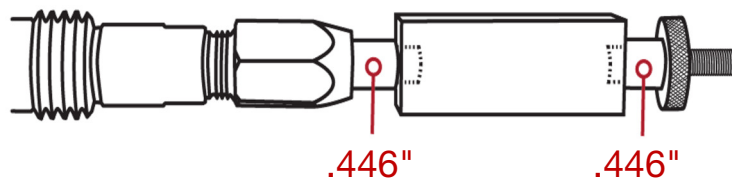

### Turning & Finishing the Blanks:

Turn the blank to your desired profile, leaving the blank slightly proud of the bushings. With the lathe spinning, begin sanding with 120-grit paper, progress through the finer grits, finishing at 320-grit. Once finished with sanding, apply a finish of your choice.

## Law Enforcement Click Pen Kit

Product : #163655

10/19/20

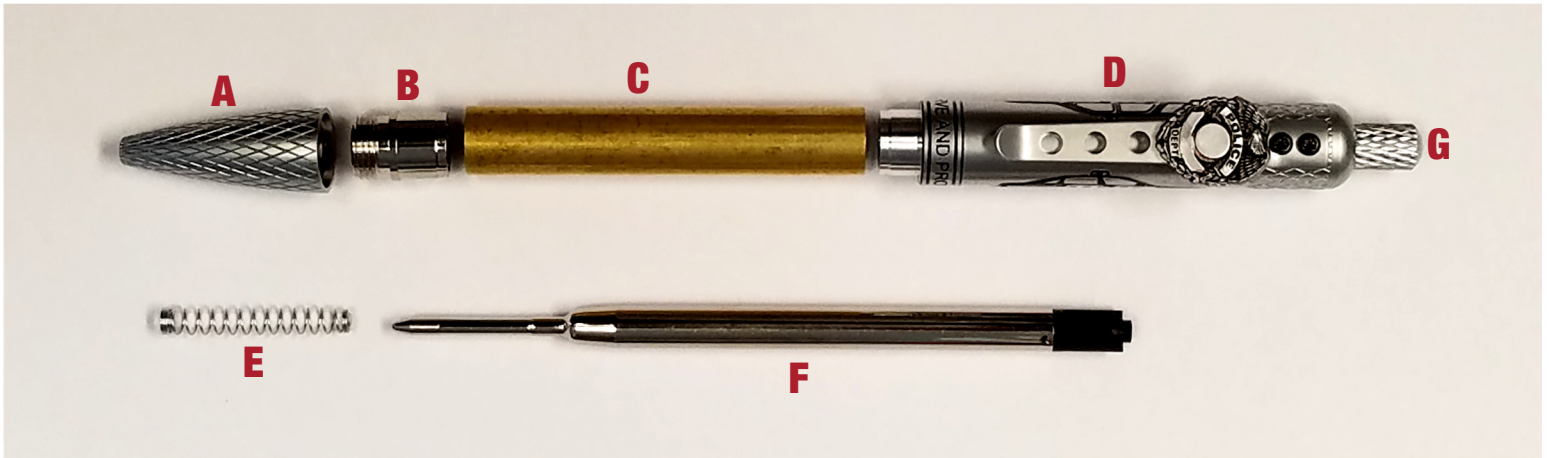

### Assembly:

- Press Threaded Nib Adapter (B) tapered end first into one end of Finished Barrel (C).
- Using a scrap piece of wood create a press block by drilling a  $\frac{1}{4}$ " diameter x  $\frac{1}{2}$ " deep hole. Insert Click Button (G) into the previously drilled hole and press the Upper Assembly (D) into the open end of Finished Barrel (C).
- Slide Spring (E) small end first onto Ink Refill (F). Insert Ink Refill Assembly (E, F) plastic end first through the opening of the Threaded Nib Adapter (B).
- Finish the assembly by threading Nib (A) onto Threaded Nib Adapter (B).